

Installation instructions

i Refer to installation use and maintenance manual for more information.
Available user manual at link <http://www.everelettronica.it/manhw.html>



Brushless AC Servo drive technical data **VANADIO**

VANADIO
AC - SERVO - DRIVES

- AC supply: 100 ÷ 240 Vac (monophase)
- Phase current: up to 3.0 Arms (peak of 12 Arms for 1s max with DCmax = 10%)
- Motor power: up to 750W
- Chopper frequency: ultrasonic 40 kHz
- Protections against: over current, over/under voltage, overheating, short circuit between motor phase-to-phase and phase-to-ground
- Canbus + Modbus RTU or Ethernet or EtherCAT or Profinet communication interfaces
- Incremental Encoder Input: 5V Differential (RS422) or 5V single-ended TTL/CMOS (isolated)
- Hall input: 5V Single-Ended (TTL/CMOS) hall effects (isolated)
- Absolute Encoder Input: 5V BiSS-C or SSI interface (isolated)
- Safe Torque Off (STO) inputs (isolated)
- Service SCI interface for programming and real time debugging
- up to 16 digital inputs (isolated)
- up to 12 digital outputs (isolated)
- up to 2 analog inputs (isolated)
- up to 2 analog outputs (isolated)
- Dimensions: see image below (without connectors)
- Protection degree: IP20
- Pollution degree 2
- Overvoltage Category III
- Short Circuit Current: 5 KA
- Protection Class: Class I Equipment
- Working temperature 5°C ÷ 50°C; Storage temperature -25°C ÷ 55°C
- Humidity: 5% ÷ 85% not condensing

error less servo efficient
else
Technology
by Ever Elettronica

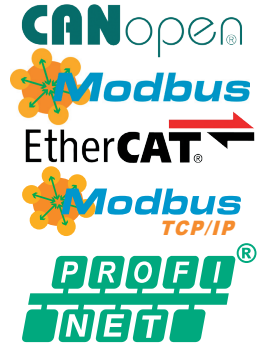

Mechanical data

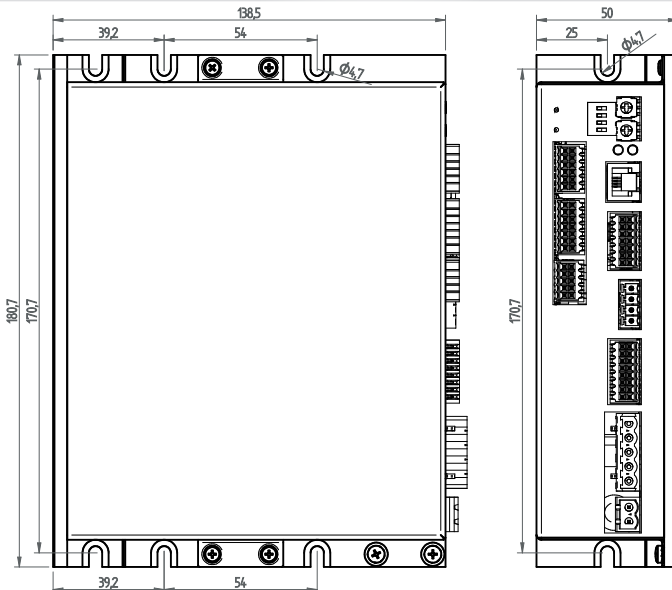

Available models

System code	STO	Communication interfaces	Digital inputs	Digital outputs	Analogue inputs	Analogue Outputs
AW5A9750L221-20	Yes	Canbus + Modbus RTU	4	3	0	0
AW5A9750L2G1-20	Yes	Canbus + Modbus RTU	16	12	2	2
AW5A9750E2G1-20	Yes	Ethernet (Modbus TCP/IP)	16	12	2	2
AW5A9750H221-20	Yes	EtherCAT	4	3	0	0
AW5A9750T221-20	Yes	Profinet	4	3	0	0

System connections

Connectors:

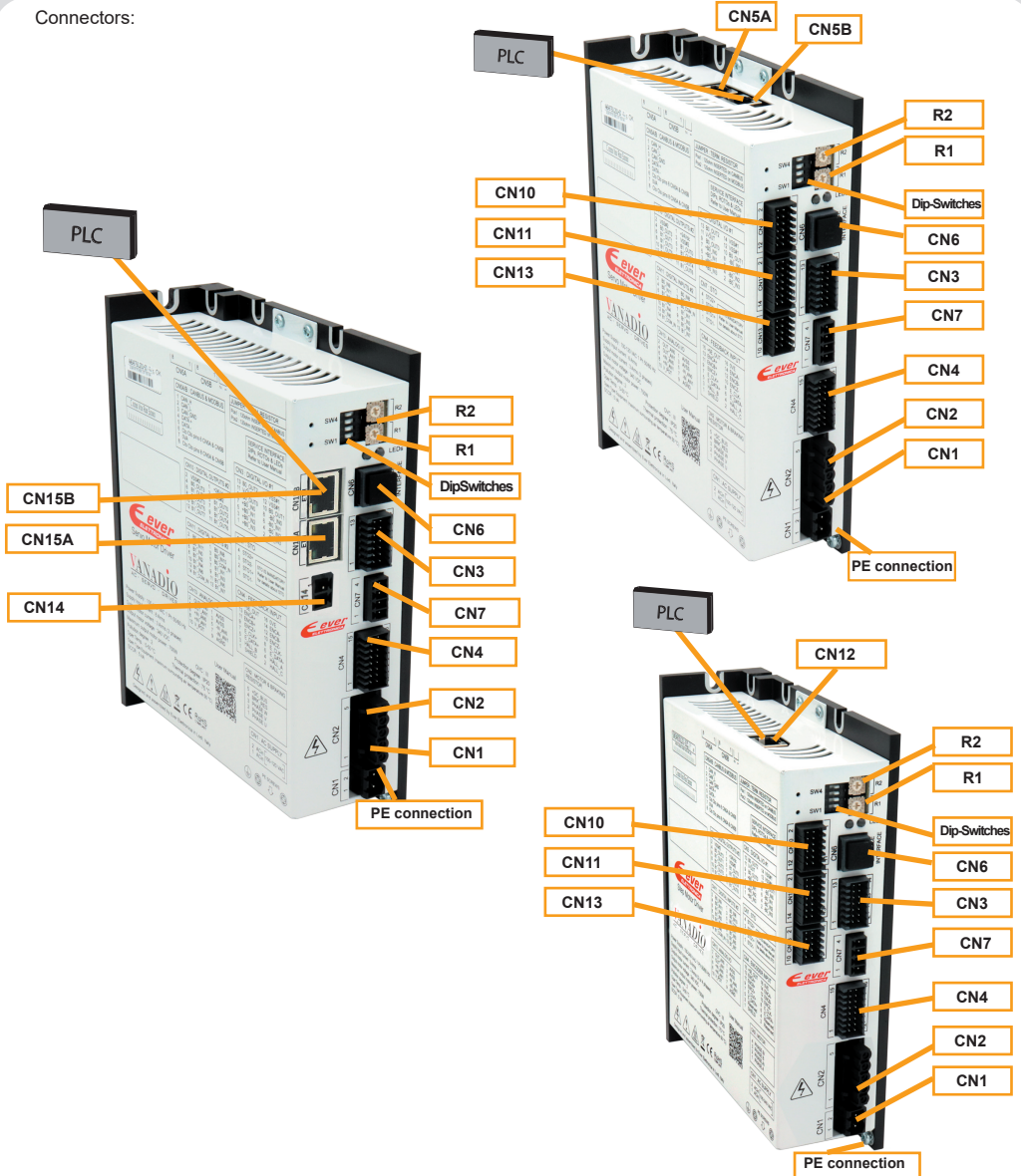

System connection

CN1: AC Power supply

2 positions, pitch 5.08mm, PCB header connector

CN1.1	ACin	PWR_IN	AC power supply input
CN1.2	ACin	PWR_IN	AC power supply input



CN2: Motor connection

5 position, pitch 5.08mm single row, PCB socket connector

CN2.1	U	PWR_OUT	Motor phase U
CN2.2	V	PWR_OUT	Motor phase V
CN2.3	W	PWR_OUT	Motor phase W
CN2.4	BRK_RES	PWR_OUT	Braking resistor input
CN2.5	+DC_BUS	PWR_OUT	DC bus output

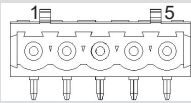

CN6: Service SCI Interface

RJ11, 6P4C, PCB header connector

CN6.1	TX/RX	Transmit / Receive Line	
CN6.2	DE/RE	Drive Enable Negated / Receive Enable	
CN6.3	+5V	+5V power out	
CN6.4	GND	GND power out	



NOTE: This connection is *only* possible with harAWARE and software provided by Ever Elettronica.

CN7: STO inputs (mandatory)

4 positions, pitch 3.81mm, PCB header connector

CN7.1	STO1 -	PWR_IN	STO1 input negative side
CN7.2	STO1 +	PWR_IN	STO1 input positive side
CN7.3	STO2 -	PWR_IN	STO2 input negative side
CN7.4	STO2 +	PWR_IN	STO2 input positive side

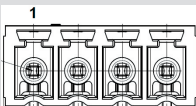

STO inputs are 24Vdc MANDATORY and ISOLATED

CN5A and CN5B: CANbus & Modbus Interfaces

RJ45, 8 position shielded, PCB header connector

CN5.1		CAN_H	DIGITAL_I/O	Bus Line Dominant HIGH (Canbus)
CN5.2		CAN_L	DIGITAL_I/O	Bus Line Dominant LOW (Canbus)
CN5.3		CAN_GND	PWR_OUT	Signal Ground for Canbus
CN5.4		Data +	DIGITAL_I/O	Positive RS485 signal (Modbus)
CN5.5		Data -	DIGITAL_I/O	Negative RS485 signal (Modbus)
CN5.6	Cto Cto between pins 6 of CN5A and CN5B		---	IN-OUT for CAN_SHLD (Canbus)
CN5.7		0V_A	PWR_OUT	Signal Ground for Modbus
CN5.8	Cto Cto between pins 8 of CN5A and CN5B		---	IN-OUT for CAN_V+ (Canbus)

1



CN3: Digital Inputs / Outputs

14 positions, pitch 2.54mm double row, PCB header connector

CN3.1	+B0_IN3	DIG_IN	Digital B0_IN3 positive side
CN3.2	-B0_IN3	DIG_IN	Digital B0_IN3 negative side
CN3.3	+B0_IN2	DIG_IN	Digital B0_IN2 positive side
CN3.4	-B0_IN2	DIG_IN	Digital B0_IN2 negative side
CN3.5	+B0_IN1	DIG_IN	Digital B0_IN1 positive side
CN3.6	-B0_IN1	DIG_IN	Digital B0_IN1 negative side
CN3.7	+B0_IN0	DIG_IN	Digital B0_IN0 positive side
CN3.8	-B0_IN0	DIG_IN	Digital B0_IN0 negative side
CN3.9	B0_OUT0	DIG_OUT	PNP digital output B0_OUT0
CN3.10	B0_OUT1	DIG_OUT	PNP digital output B0_OUT1
CN3.11	V-OUT	PWR_IN	24 Vdc supply for digital output
CN3.12	VSS	PWR_IN	Negative input supply for digital output
CN3.13	B0_OUT2	DIG_OUT	PNP digital output B0_OUT2
CN3.14	VSS	PWR_IN	Negative input supply for digital output

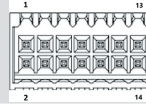

CN4: Feedback connection

16 position, pitch 2.54mm double row, PCB header connector

CN4.1	SHIELD	/	Cable shield connection for feedback interface
CN4.2	HALL_C	DIG_IN	Hall effect signal C input
CN4.3	HALL_B	DIG_IN	Hall effect signal B input
CN4.4	HALL_A	DIG_IN	Hall effect signal A input
CN4.5	DATA+	DIG_IN	Absolute encoder data input positive
CN4.6	DATA-	DIG_IN	Absolute encoder data input negative
CN4.7	CLK+	DIG_OUT	Absolute encoder clock output positive
CN4.8	CLK-	DIG_OUT	Absolute encoder clock output negative
CN4.9	ENCZ+	DIG_IN	Encoder Zero differential input positive
CN4.10	ENCZ-	DIG_IN	Encoder Zero differential input negative
CN4.11	ENCB+	DIG_IN	Encoder Phase B differential input positive
CN4.12	ENCB-	DIG_IN	Encoder Phase B differential input negative
CN4.13	ENCA+	DIG_IN	Encoder Phase A differential input positive
CN4.14	ENCA-	DIG_IN	Encoder Phase A differential input negative
CN4.15	+5E	PWR_OUT	+5Vdc power supply output
CN4.16	0VE	PWR_OUT	Negative side of supply

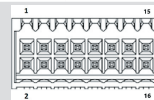

System connection

CN10: Digital Outputs #2

12 positions, pitch 2.54mm double row, PCB header connector

CN10.1	+24Vdc	PWR_IN	24Vdc supply for digital outputs on CN10
CN10.2	VSS#2	PWR_IN	Negative reference for digital outputs on CN10
CN10.3	VSS#2	PWR_IN	Negative reference for digital outputs on CN10
CN10.4	B0_OUT3	DIG_OUT	PNP digital output B0_OUT3
CN10.5	B1_OUT0	DIG_OUT	Digital output B1_OUT0 (PNP)
CN10.6	B1_OUT1	DIG_OUT	Digital output B1_OUT1 (PNP)
CN10.7	B1_OUT2	DIG_OUT	Digital output B1_OUT2 (PNP)
CN10.8	B1_OUT3	DIG_OUT	Digital output B1_OUT3 (PNP)
CN10.9	B1_OUT4	DIG_OUT	Digital output B1_OUT4 (PNP)
CN10.10	B1_OUT5	DIG_OUT	Digital output B1_OUT5 (PNP)
CN10.11	B1_OUT6	DIG_OUT	Digital output B1_OUT6 (PNP)
CN10.12	B1_OUT7	DIG_OUT	Digital output B1_OUT7 (PNP)

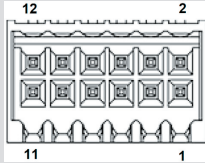

CN13: Analog I/O

10 positions, pitch 2.54mm double row, PCB header connector

CN13.1	AVSS	PWR_OUT	Negative output reference for analog outputs
CN13.2	OUT_AN0	AN_OUT	Analog output 0 positive side
CN13.3	AVSS	PWR_OUT	Negative output reference for analog outputs
CN13.4	OUT_AN1	AN_OUT	Analog output 1 positive side
CN13.5	-IN_AN0	AN_IN	Analog input 0 negative side
CN13.6	+IN_AN0	AN_IN	Analog input 0 positive side
CN13.7	-IN_AN1	AN_IN	Analog input 1 negative side
CN13.8	+IN_AN1	AN_IN	Analog input 1 positive side
CN13.9	AGND	PWR_OUT	Negative output reference for potentiometer
CN11.10	VPOT	PWR_OUT	Voltage supply output for potentiometers

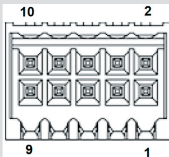

CN15A and CN15B: EtherCAT Interface

RJ45, 8 position shielded, PCB header connector

Dual RJ45 connectors (IN-OUT)

100BASE-TX (100Mb/sec) ports

Accept standard Ethernet cable (CAT5 or higher)



CN15A (OUT)



CN15B (IN)

EtherCAT

CN15A and CN15B: Profinet Interface

RJ45, 8 position shielded, PCB header connector

Dual RJ45 connectors (P1-P2)

100BASE-TX (100Mb/sec) ports

Accept standard Ethernet cable (CAT5 or higher)



CN15A (P1)



CN15B (P2)

PROFI[®]
NET

CN12: Ethernet Interface

RJ45, 8 position shielded, PCB header connector

Dual RJ45 connectors (IN-OUT)

100BASE-TX (100Mb/sec) ports

Accept standard Ethernet cable (CAT5 or higher)



CN12

Modbus
TCP/IP

CN11: Digital Inputs #2

14 positions, pitch 2.54mm double row, PCB header connector

CN11.1	B0_IN8	DIG_IN	Digital input B0_IN8
CN11.2	B0_IN9	DIG_IN	Digital input B0_IN9
CN11.3	B0_IN10	DIG_IN	Digital input B0_IN10
CN11.4	B0_IN11	DIG_IN	Digital input B0_IN11
CN11.5	B0_COM_IN	PWR_IN	Reference common inputs B0 on CN11
CN11.6	B1_IN0	DIG_IN	Digital input B1_IN0
CN11.7	B1_IN1	DIG_IN	Digital input B1_IN1
CN11.8	B1_IN2	DIG_IN	Digital input B1_IN2
CN11.9	B1_IN3	DIG_IN	Digital input B1_IN3
CN11.10	B1_IN4	DIG_IN	Digital input B1_IN4
CN11.11	B1_IN5	DIG_IN	Digital input B1_IN5
CN11.12	B1_IN6	DIG_IN	Digital input B1_IN6
CN11.13	B1_IN7	DIG_IN	Digital input B1_IN7
CN11.14	B1_COM_IN	PWR_IN	Reference common inputs B1 on CN11

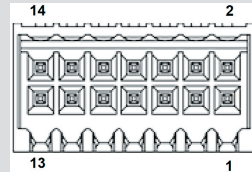

CN14: 24 Vdc Expansion Supply

2 positions, pitch 5.08mm, PCB header connector

CN14.1	VIN_EXP	PWR_IN	Positive DC expansion supply
CN14.2	VSS_EXP	PWR_IN	Negative expansion supply

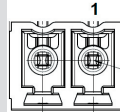

24 Vdc MANDATORY and ISOLATED

JUMPERS - Terminator Resistor

Position 1 120 ohm resistor INSERTED on Canbus network

Position 2 120 ohm resistor INSERTED on Modbus network

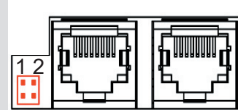

Service SCI connection



This connection is only possible with hardware and software provided by Ever.
Kit code: SW5_SERV00-SL or SW5-SERV00-EE.

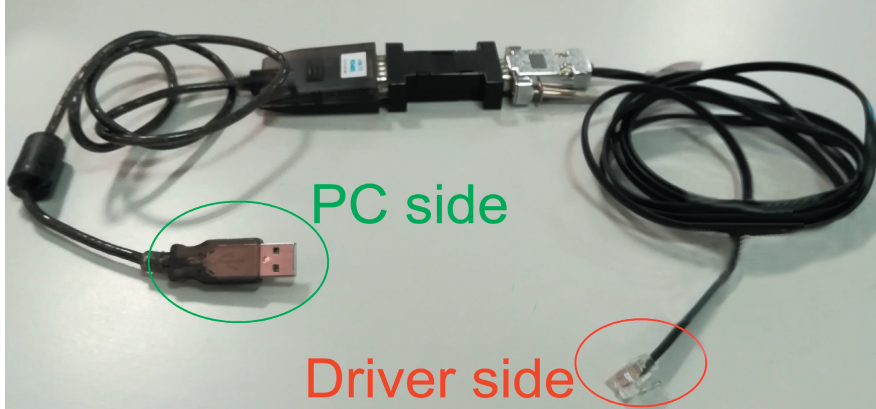

Dip-Switches and Roto-Switches settings

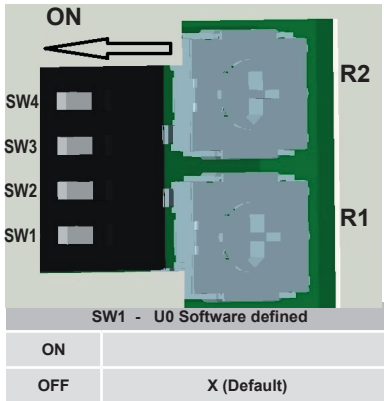

Drives's Baud Rate Selection				
SW2	SW3	SW4	Modbus	Canbus
OFF	OFF	OFF	115200	1 M
OFF	OFF	ON	57600 (default)	500 K (default)
OFF	ON	OFF	38400	250 K
OFF	ON	ON	19200	125 K
ON	OFF	OFF	9600	100 K
ON	OFF	ON	4800	50 K
ON	ON	OFF	2400	50 K
ON	ON	ON	1200	50 K

Node-ID Selection										
R2	0	0	0	0	...	2	2	...	7	7
R1	0	1	2	3	...	C	D	...	E	F
Node-ID #	Reserved	1 (default)	2	3	...	44	45	...	126	127

Reserved													
8	8	F	F						
0	1	E	F						
Reserved													



NOTE: the device reads the Dip-Switches and the Roto-Switches only during the Power up. If it's necessary a setting change, shut down the system, change the settings and start up the system again to make the changes operating.



In EtherCAT, Profinet and Ethernet versions the functionality of the Dip-Switches & Roto-Switches depends on the Firmware installed on the drive (Refer to the Software Manual).

Working Status (LED)

Visualization status		Description
1		Green ON Correct functioning.
2		Green BLINKING Enable OFF, current zero
3		Blue ON Error: connect with Service SCI kit and check with software
4		Blue ON Yellow ON Drive in boot mode. A new firmware should be downloaded to drive
5		Blue ON Red BLINKING (200 ms) Initialization phase. Should last few seconds. While in this condition the drive is not fully operational.
6		Yellow ON Missing setting of Inominal
7		Yellow BLINKING (500 ms) Warning: connect with Service SCI kit and check with software
8		Red ON Protection: motor is in open phase condition
9		Red BLINKING (200 ms) Current protection
10		Red ON (1 sec) Yellow 1 BLINK Under/Over voltage protection
11		Red ON (1 sec) Yellow 3 BLINK Thermal protection
12		Red ON (1 sec) Yellow 4 BLINK Motor Feedback Error
13		Red ON (1 sec) Yellow 5 BLINK Missing Safe Torque Off
14		Red ON (1 sec) Yellow 6 BLINK Motor Current Regulation is out of range
15		Red ON (1 sec) Yellow 7 BLINK eePLC User Protection (generated by setting bit #0 of eePLC_User_Settings)



Note: Drive could be considered in a correct status if leds Red, Yellow and Blue are all OFF.
In general : - Led Blue indicates a software internal fault or a non-operative condition
 - Led Red indicates an alarm or a drive protection
 - Led Yellow indicates a warning

Power & Logic Supply connections

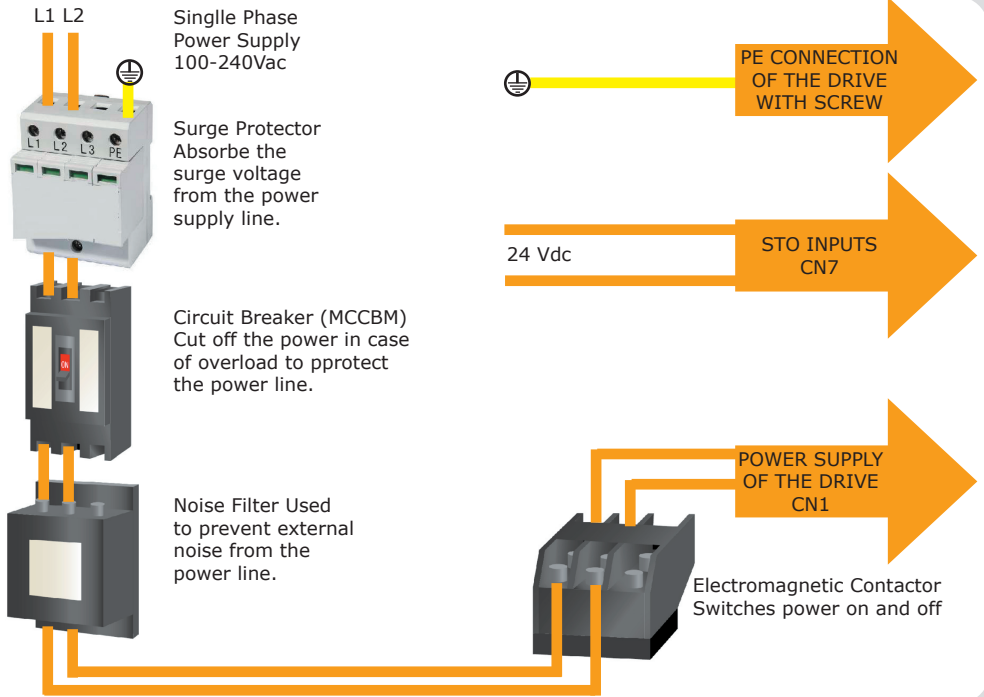

Absolute Encoder input connection (isolated)

(Maximum supply current 100mA)

Differential 5Vdc digital inputs that meet the RS422 standard.

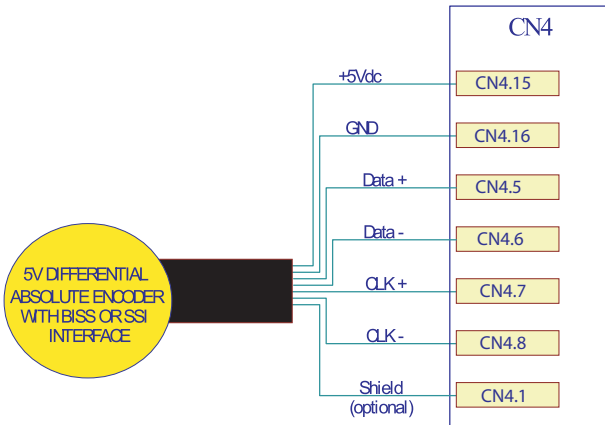

Incremental Encoder input connection (isolated)

(Maximum supply current 100mA)

Differential 5Vdc digital inputs that meet the RS422 standard.

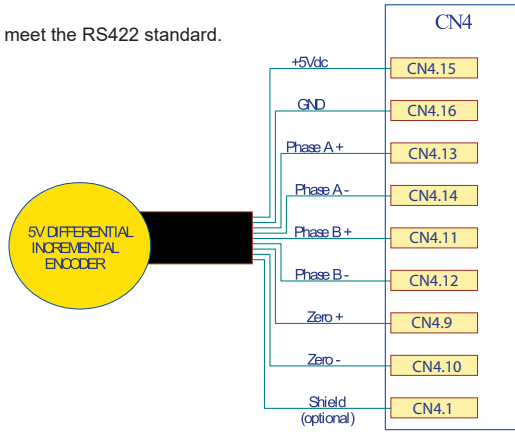

Single-Ended 5Vdc TTL/CMOS digital inputs

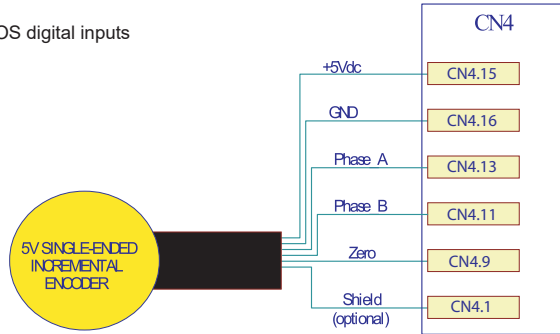

Hall signals input connection

(Maximum supply current 100mA)

Single-Ended 5Vdc TTL/CMOS digital inputs.

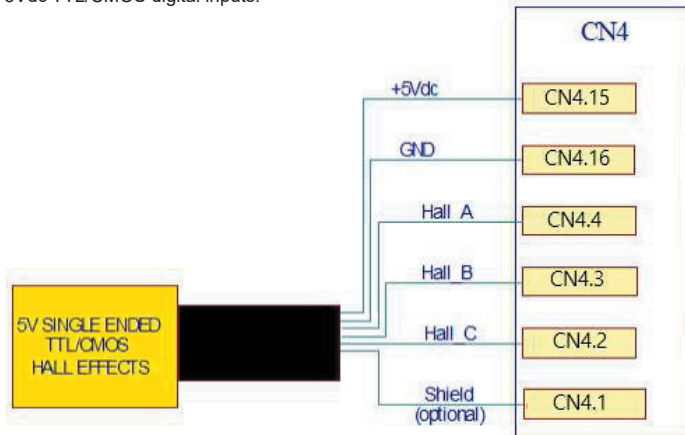

Safe Torque Off inputs (STO)

2 terminals, 24V compatible (optoisolated)

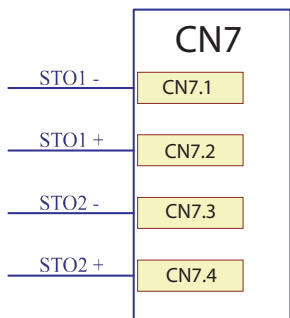

STO1	STO2	Drive Status	Motor Status
+24Vdc	+24Vdc	Enable	SW controlled
+24Vdc	Not connected	Disable	Stop for inertia
Not connected	+24Vdc	Disable	Stop for inertia
Not connected	Not connected	Disable	Stop for inertia



STO inputs are optoisolated.

Safety specifications

Safety function	STO	Safe Torque Off
Category	4	In accordance with EN ISO 13849-1
Performance Level	PLe	In accordance with EN ISO 13849-1
Safety Integrity Level	SIL3	In accordance with EN ISO 13849-1 table 3
DC _{avg}	[%]	99
		Average Diagnostic Coverage
PFH _D	[1/h]	7,04 x 10 ⁻⁹
		Probability of dangerous failure per hour
T Service Life	[Years]	20
		In accordance with EN ISO 13849-1
Type test	The STO function has been certified by an independent testing body.	

i Refer to the 'Safety Manual_STO on SW5A9030-AW5A9750-AW5A6750 Serie_GB_R00' for more details of the Safe Torque Off function characteristics.

Principle of operation:

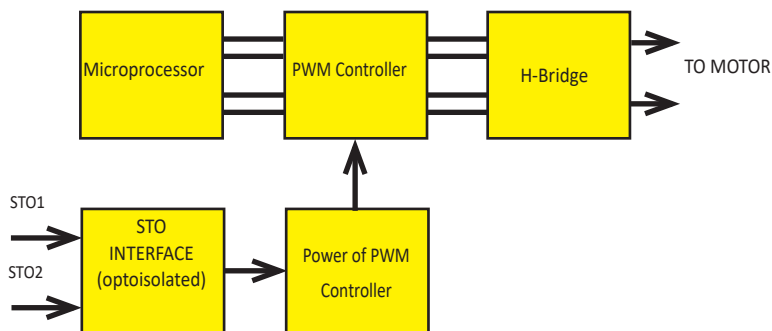

The drive has a safety feature that is designed to provide the Safe Torque Off (STO) function. Two input signals are provided which, when not connected, prevent the upper and lower devices in the PWM outputs from being operated by the digital control core. This provides a positive OFF capability that cannot be overridden by the control firmware, or associated hardware components. When both STO signals are activated (current is flowing in the input diodes of the optocouplers), the control core will be able to control the on/off state of the PWM outputs.



If not using the STO feature, both signals must be connected to a 24Vdc supply in order to enable the drive.



If a drive in operation mode is disabled by STO signal, it immediately finishes to produce torque but the motor continues to run by inertia until it can stop.

Braking Resistor connection

Internal circuit drives a braking resistor when the mechanical energy of the motor is converted back into electrical energy that must be dissipated before it charges the internal capacitors to an overvoltage condition.

Cut-In Voltage $+DC_BUS > 390 \text{ Vdc}$: output is on, external braking resistor is dissipating energy

Drop-Out Voltage $+DC_BUS < 380 \text{ Vdc}$: output is off, regen resistor not dissipating energy

Tolerance $\pm 2 \text{ Vdc}$ for either Cut-In or Drop-Out voltage

DC Bus Capacitance : 750uF

Input voltage	Energy Absorption Capacity of the DC Bus
100 Vac	49.54 joules
120 Vac	46.24 joules
240 Vdc	13.84 joules

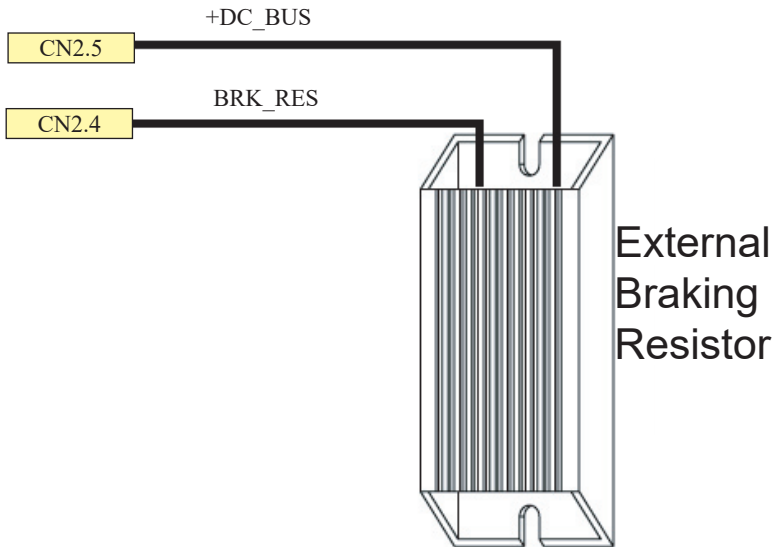

External braking resistor must be placed more than 50mm from the drive on nonflammable and heat resistant surfaces. The metal case of the braking resistor can reach high temperatures. Take all necessary measures to avoid possible contacts in the final installation.



+DC_BUS is an High-Voltage circuit (up to 400Vdc) so take all necessary measures to avoid possible contacts in the final installation.

Digital inputs connection

B0_IN0 to B0_IN3 inputs



Differential PNP, NPN and Line Driver type (isolated)

5 - 24Vdc INPUTS

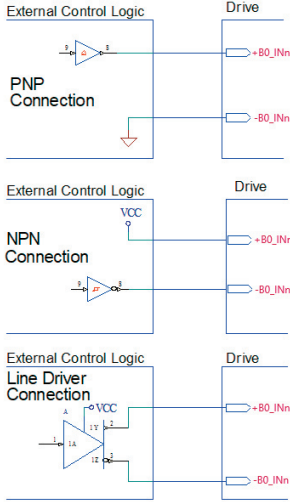

Standard (B0_IN0 and B0_IN1)

Characteristics	MIN.	MAX.	Unit
Supply voltage	5	24	Vdc
Inputs frequency	--	10	kHz
Threshold switching voltage	1.9	2.4	Vdc
Current at 5 Vdc	--	6.28	mA
Current at 24 Vdc	--	8.75	mA

High speed (B0_IN2 and B0_IN3)

Characteristics	MIN.	MAX.	Unit
Supply voltage	5	24	Vdc
Inputs frequency	--	250	kHz
Threshold switching voltage	1.9	2.4	Vdc
Current at 5 Vdc	--	7.52	mA
Current at 24 Vdc	--	10	mA

B1_IN0 to B1_IN7 inputs



Single-Ended PNP, NPN, Push-Pull (isolated)

N.B.: All these inputs must be connected with the same configuration (PNP, NPN or Push-Pull).

Standard (B1_IN0 to B1_IN7)

Characteristics	MIN.	MAX.	Unit
Supply voltage	5	24	Vdc
Inputs frequency	--	250	Hz
Threshold switching voltage	2.5	--	Vdc
Current at 5 Vdc	--	2	mA
Current at 24 Vdc	--	12	mA

B0_IN8 to B0_IN11 inputs



Single-Ended PNP, NPN, Push-Pull (isolated)

N.B.: All these inputs must be connected with the same configuration (PNP, NPN or Push-Pull).

5 - 24V INPUT

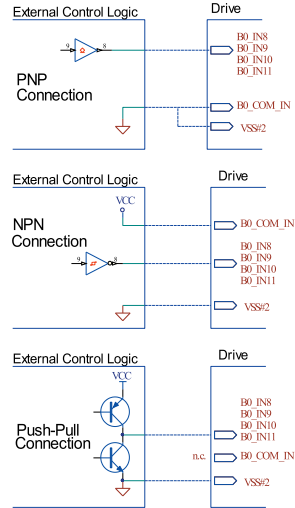

Standard (B0_IN8 to B0_IN11)

Characteristics	MIN.	MAX.	Unit
Supply voltage	5	24	Vdc
Inputs frequency	--	100	kHz
Threshold switching voltage	2	--	Vdc
Current at 5 Vdc	--	2	mA
Current at 24 Vdc	--	12	mA

5 - 24V INPUT

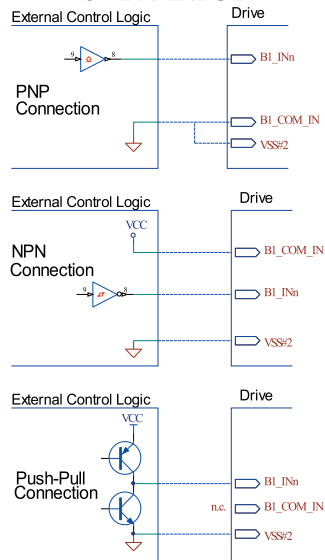

Digital outputs connection

B0_OUT0 and B0_OUT1

i PNP with $V_{OUTmax}=24Vdc$, $I_{OUTmax}=100mA$, $F_{max} = 250\text{ kHz}$ (isolated)

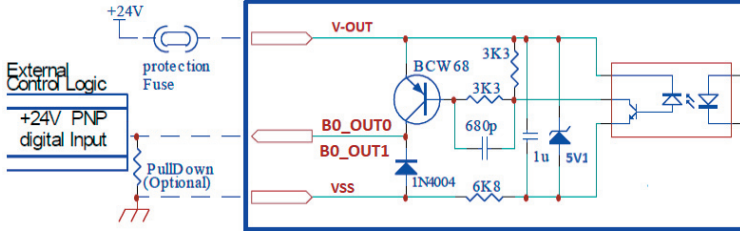

B0_OUT2

i PNP with $V_{OUTmax}=24Vdc$, $I_{OUTmax}=1.3A$, $F_{max} = 1\text{ kHz}$ (isolated)

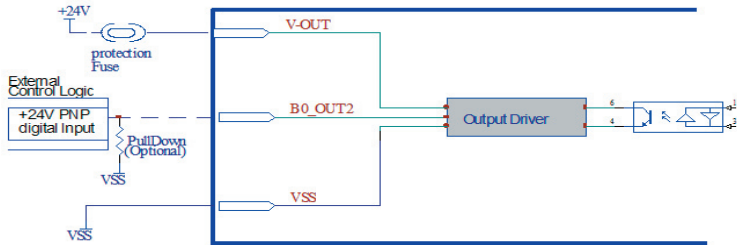

B0_OUT3

i PNP with $V_{OUTmax}=24Vdc$, $I_{OUTmax}=500mA$, $F_{max} = 1\text{ kHz}$ (isolated)

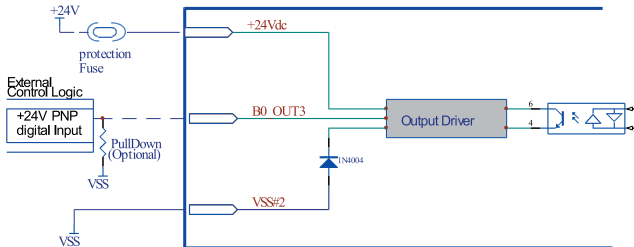

B1_OUT0 to B1_OUT7

i PNP with $V_{OUTmax}=24Vdc$, $I_{OUTmax}=100mA$, $F_{max} = 250\text{ Hz}$ (isolated)

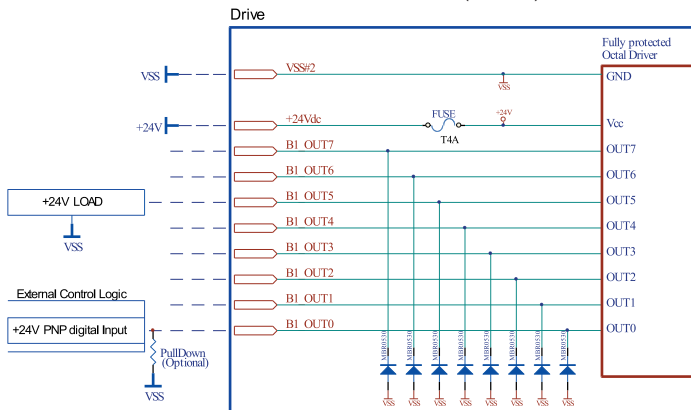

Analog inputs connection

i Isolated configurable analog inputs. The resolution of the analog inputs depends from the type of the connection which could be defined by software: differential or potentiometer.

DIFFERENTIAL CONNECTION

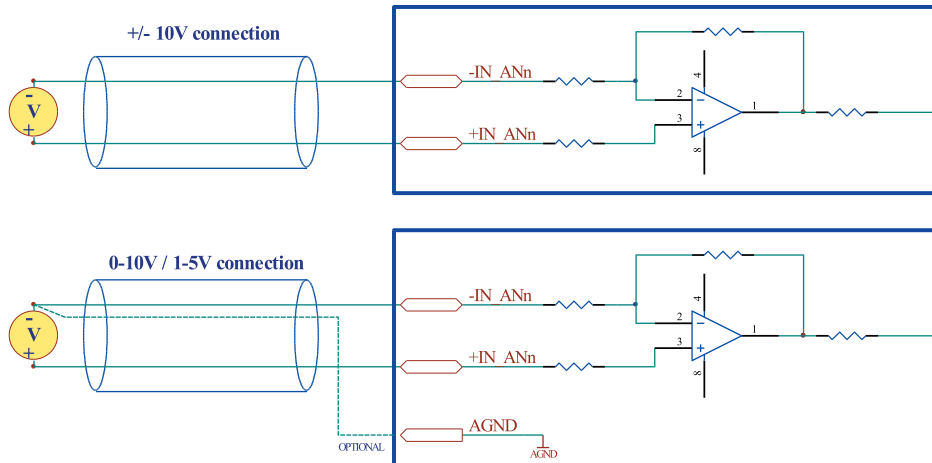

POTENTIOMETER CONNECTION

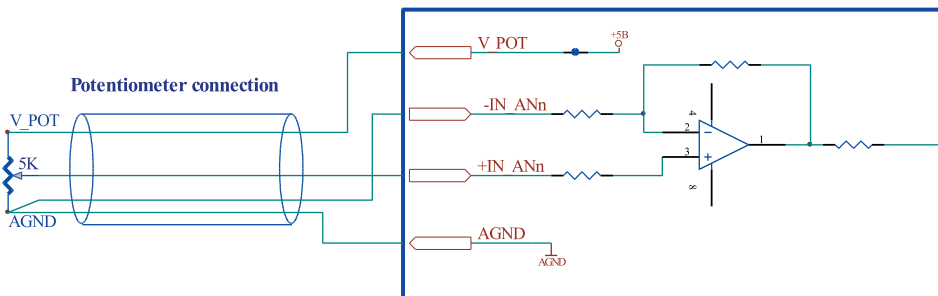

Analog outputs connection

i 0-10V isolated analog outputs

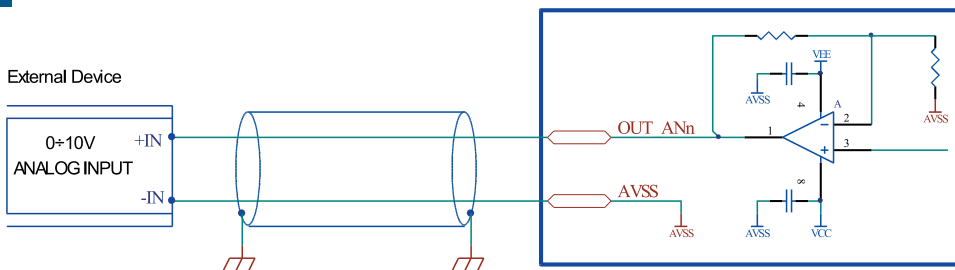

Mating connectors

Connector	Description
CN1	Phoenix 1758856
CN2	Phoenix 1920972
CN3	Dinkle 0156-1B14-BK
CN4	Dinkle 0156-1B16-BK
CN5A / CN5B	RJ45 8 positions

Connector	Description
CN7	Phoenix 1839636
CN10	Dinkle 0156-1B12-BK
CN11	Dinkle 0156-1B14-BK
CN12	Ethernet standard cables (CAT5 or higher)
CN13	Dinkle 0156-1B10-BK
CN14	Phoenix 1827635
CN15A / CN15B	Ethernet standard cables (CAT5 or higher)

Section of the cables

Function	Cable	
	Minimum	Maximum
Power supply and PE	0.5 mm ² (AWG20)	2.5 mm ² (AWG12)
Motor output	0.5 mm ² (AWG20)	2.5 mm ² (AWG12)
Feedback	0.12 mm ² (AWG26)	0.5 mm ² (AWG20)
Inputs / Outputs	0.12 mm ² (AWG26)	1.3 mm ² (AWG16)
CANbus/Modbus interface	Min. 0.25 mm ² (AWG23) CANbus CiA-CANOpen	
Ethernet interfaces	Ethernet standard cables (CAT5 or higher)	

Verify the installation

- Check all connection: power supply, logic supply and inputs/outputs.
- Make sure all settings right for the application.
- Make sure the power supply is suitable for the drive.
- If possible, remove the load from the motor shaft to avoid that wrong movements cause damage.
- Enable the current to the motor and verify the applied torque.
- Enable a movement of some steps and verify if the rotation direction is the desired one.
- Disconnect the power supply, connect the load on the motor and check the full functionality.

Drive's fault analysis



When any of the following situations occur, the drive is placed in a fault condition.

DEFECT	CAUSE	ACTION
Intervention of the thermal protection.	Can be caused by a heavy working cycle or a high current in the motor.	Improve the drive cooling by natural or fan air flow. Consider to use a motor with a higher torque vs current rating.
Intervention of the current protection.	Short circuit on the motor powering stage(s) of the drive.	Check motor windings and cables to remove the short circuits replacing faulty cables or motor if necessary.
Intervention of the over/under voltage protection.	Supply voltage out of range.	Check the value of the supply voltage.
Open phase motor protection.	Motor windings to drive not proper connection.	Check motor cables and connections to the drive.



When any of the following situations occur, the drive doesn't work and isn't placed in an error condition.

DEFECT	CAUSE	ACTION
Noisy motor movement with vibrations.	Can be caused by a lack of power supply to a phase of the motor or a poor regulation of the winding current.	Check the cables and connections of the motor and/or change the motor speed to avoid a resonance region.
The external fuse on the power supply of the drive is burned.	Can be caused by a wrong connection of the power supply.	Connect the power supply correctly and replace the fuse.
At high speed, the motor torque is not enough.	Can be due to a 'self-limitation' of motor current and torque.	Increase the motor current or increase the supply voltage (always within the limits of the motor).

UL regulation requirements

In order to comply with cURus certification according to the UL 61800-5-1 standard, the following requirements must be met:



Electrical ratings

INPUT

Input Voltage Range	Maximum Input Current
100/50 - 240/120 VAC 1 Ph 50/60 Hz	3.0 Arms

The drive must be supplied by single-phase (split-phase) three-wire system a.c.

Phase-to-Phase / Phase-to-Earth Voltage
100/50 - 240/120 VAC 1 Ph

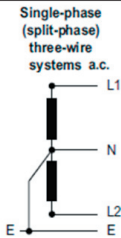

OUTPUT

Maximum Output Voltage	Motor Phases Number	Maximum Output Current	Maximum Output Motor Power
340 Vdc	3	3.0 Arms	0,75 kW

- Maximum length of the cables

Cables	Length
AC Power Supply	No limitation
Motor	No limitation
STO Inputs	No limitation
Feedback	< 30m
Input & Output	< 30m
Fieldbus	< 30m

- Motor cable must be shielded

- Solid state short circuit protection

Integral solid state short circuit protection does not provide branch circuit protection. Branch circuit protection must be provided in accordance with the Manufacturer Instructions, National Electrical Code and any additional local codes.

- External Fuses and Short Circuit Protection on Supply

Suitable for use on a circuit capable of delivering not more than 5000 Arms symmetrical amperes, 250 Vac maximum when protected by semiconductor fuses model FWX-20A14F by Cooper Bussmann LLC

- Discharge time of the capacitors on the AC power supply



WARNING/CAUTION – Risk of Electric Shock

Wait at least No. 153 seconds (3 minutes) after disconnecting AC power supply
Time required for the capacitors to a safe discharge to a level below 50 Vdc.

EVER Elettronica

Via del Commercio, 2/4 - 9/11
Loc. San Grato Z. I

26900 - L O D I - Italy

Phone +39 0371 412318 - Fax +39 0371 412367

email: infoever@everelettronica.it

web: www.everelettronica.it

