

## Installation instructions

**i** Refer to installation use and maintenance manual for more information.  
Available user manual at link <http://www.everelettronica.it/manhw.html>



## Brushless AC Servo drive technical data :

- AC power supply: 85-265Vac monophasic or triphasic
- DC logic supply: 24 Vdc (mandatory and isolated)
- Phase current: up to 5.2 Arms
- Chopper frequency: ultrasonic 40kHz
- Protections against: over current, over/under voltage, overheating, short circuit between motor phase-to-phase and phase-to-ground;
- EtherCAT communication interface
- Incremental Encoder Input: 5V Differential (RS422) or 5V single-ended TTL/CMOS
- Hall Signals Input: 5V single-ended TTL/CMOS
- Incremental Encoder Output: 5V Differential (RS422)
- Absolute Encoder Input: 5V BiSS-C or SSI interface
- Service SCI interface for programming and real time debugging
- Safe Torque Off (STO) inputs (opto-coupled)
- 4 digital inputs (opto-coupled)
- 3 digital outputs (opto-coupled)
- Dimensions: 196.6 x 136.6 x 47 mm (without connectors)
- Protection degree: IP20
- Pollution degree 2
- Overvoltage Category III
- Short Circuit Current: 5 KA
- Protection Class: Class I Equipment
- Working temperature 5°C ÷ 50°C; Storage temperature -25°C ÷ 55°C
- Humidity: 5% ÷ 85% not condensing

**VANADIO**  
AC - SERVO - DRIVES

error  
less  
servo  
efficient  
technology  
**else**  
by Ever Elettronica

**EtherCAT**®

EtherCAT® is registered trademark and patented technology,  
licensed by Beckhoff Automation GmbH, Germany.

**CE** **UL** **US**



## Mechanical data

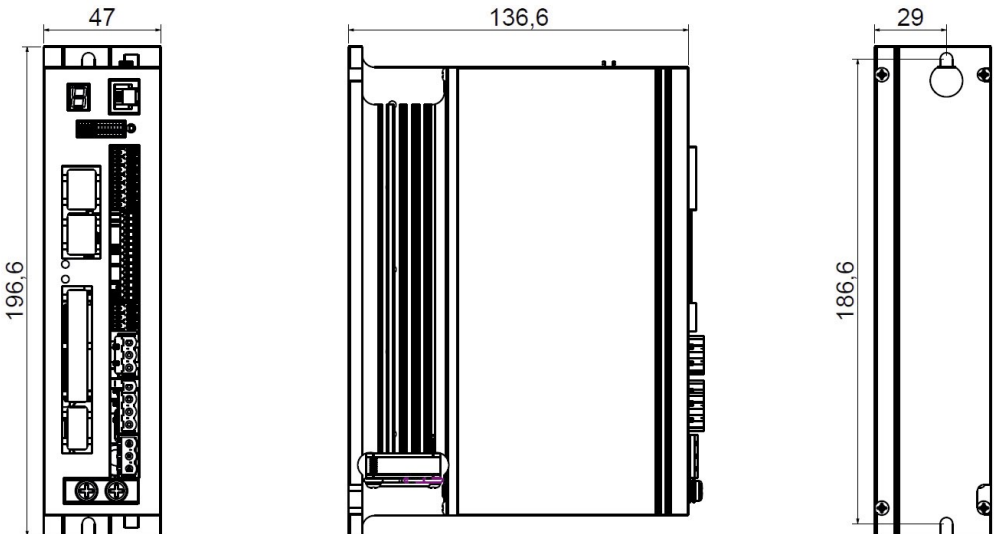

# System connections

Connectors:

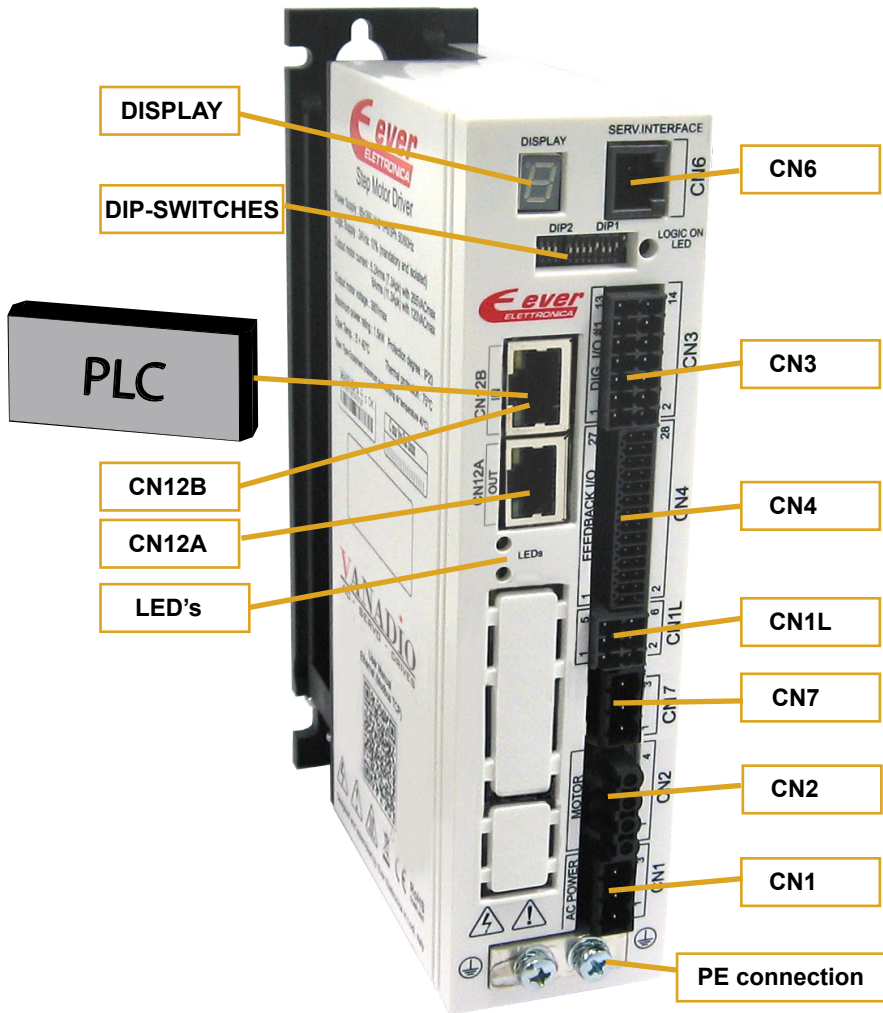

# System connection

## CN1: AC Power supply

3 positions, pitch 5.08mm double row, PCB header connector

CN1.1	ACin	PWR_IN	AC power supply input
CN1.2	ACin	PWR_IN	AC power supply input
CN1.3	ACin	PWR_IN	AC power supply input

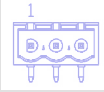

## CN7: Braking resistor

3 position, pitch 5.08mm single row connector

CN7.1	+DC_BUS	PWR_OUT	DC_BUS output
CN7.2	EXT_RES	PWR_IN	External Braking Resistor input
CN7.3	INT_RES		Reserved pin



## CN2: Motor connection

3 position, pitch 5.08mm single row, PCB socket connector

CN2.1	V	PWR_OUT	Motor phase V
CN2.2	U	PWR_OUT	Motor phase U
CN2.3	W	PWR_OUT	Motor phase W

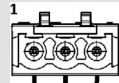

## CN1L: 24Vdc Logic Supply and STO inputs

6 positions, pitch 3.5mm double row, PCB header connector

CN1L.1	VLOG -	PWR_IN	Negative DC logic supply input
CN1L.2	VLOG +	PWR_IN	Positive DC logic supply input
CN1L.3	STO1 -	PWR_IN	STO1 input negative side
CN1L.4	STO1 +	PWR_IN	STO1 input positive side
CN1L.5	STO2 -	PWR_IN	STO2 input negative side
CN1L.6	STO2 +	PWR_IN	STO2 input positive side

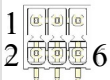

**LOGIC 24Vdc MANDATORY and ISOLATED**

## CN6: Service SCI Interface

RJ11, 6P4C, PCB header connector

CN6.1	TX/RX	Transmit / Receive Line	
CN6.2	DE/RE	Drive Enable Negated / Receive Enable	
CN6.3	+5V	+5V power out	
CN6.4	GND	GND power out	



**NOTE: This connection is only possible with hardware and software provided by Ever Elettronica.**

## CN3: Digital Inputs / Outputs #1

14 positions, pitch 3.5mm double row, PCB header connector

CN3.1	VSS#1	PWR_IN	Negative supply for digital outputs B0 on CN3
CN3.2	V-OUT	PWR_IN	24Vdc supply for digital outputs B0 on CN3
CN3.3	B0_OUT0	DIG_OUT	PNP digital output B0_OUT0
CN3.4	B0_OUT1	DIG_OUT	PNP digital output B0_OUT1
CN3.5	B0_OUT2	DIG_OUT	PNP digital output B0_OUT2
CN3.6	N.C.	---	Not connected
CN3.7	-B0_IN0	DIG_IN	Digital input B0_IN0 negative side
CN3.8	+B0_IN0	DIG_IN	Digital input B0_IN0 positive side
CN3.9	-B0_IN1	DIG_IN	Digital input B0_IN1 negative side
CN3.10	+B0_IN1	DIG_IN	Digital input B0_IN1 positive side
CN3.11	-B0_IN2	DIG_IN	Digital input B0_IN2 negative side
CN3.12	+B0_IN2	DIG_IN	Digital input B0_IN2 positive side
CN3.13	-B0_IN3	DIG_IN	Digital input B0_IN3 negative side
CN3.14	+B0_IN3	DIG_IN	Digital input B0_IN3 positive side

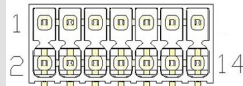

## CN4: Feedback connection

28 position, pitch 2.54mm double row, PCB header connector

CN4.1	SHIELD	/	Cable shield connection for feedback interface
CN4.2	SHIELD	/	Cable shield connection for feedback interface
CN4.3	N.C.	---	Not connected
CN4.4	N.C.	---	Not connected
CN4.5	DATA-	DIG_IN	Absolute encoder data input negative
CN4.6	DATA+	DIG_IN	Absolute encoder data input positive
CN4.7	CLK-	DIG_OUT	Absolute encoder clock output negative
CN4.8	CLK+	DIG_OUT	Absolute encoder clock output positive
CN4.9	HALL_C	DIG_IN	Hall signal C input
CN4.10	HALL_B	DIG_IN	Hall signal B input
CN4.11	HALL_A	DIG_IN	Hall signal A input
CN4.12	T_MOT	AN_IN	Temperature motor input
CN4.13	ENCZ-	DIG_IN	Encoder Zero differential input negative
CN4.14	ENCZ+	DIG_IN	Encoder Zero differential input positive
CN4.15	ENCB-	DIG_IN	Encoder Phase B differential input negative
CN4.16	ENCB+	DIG_IN	Encoder Phase B differential input positive
CN4.17	ENCA-	DIG_IN	Encoder Phase A differential input negative
CN4.18	ENCA+	DIG_IN	Encoder Phase A differential input positive
CN4.19	0VE	PWR_OUT	Negative side of supply
CN4.20	+5E	PWR_OUT	+5Vdc power supply output
CN4.21	OUT_ENCZ-	DIG_OUT	Encoder Zero differential output negative
CN4.22	OUT_ENCZ+	DIG_OUT	Encoder Zero differential output positive
CN4.23	OUT_ENCB-	DIG_OUT	Encoder Phase B differential output negative
CN4.24	OUT_ENCB+	DIG_OUT	Encoder Phase B differential output positive
CN4.25	OUT_ENCA-	DIG_OUT	Encoder Phase A differential output negative
CN4.26	OUT_ENCA+	DIG_OUT	Encoder Phase A differential output positive
CN4.27	0VE	PWR_OUT	Reference ground for feedback interface
CN4.28	0VE	PWR_OUT	Reference ground for feedback interface



## System connections

### CN12A and CN12B: EtherCAT Fieldbus Interfaces

RJ45, 8 position shielded, PCB header connector

Dual RJ45 connectors (IN-OUT)  
100BASE-TX (100Mb/sec) ports  
Accept standard Ethernet cable (CAT5 or higher)

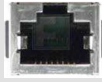

CN12A (OUT)

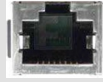

CN12B (IN)

## Service SCI connection



*This connection is only possible with hardware and software provided by Ever.  
Kit code: SW5\_SERV00-SL or SW5-SERV00-EE.*

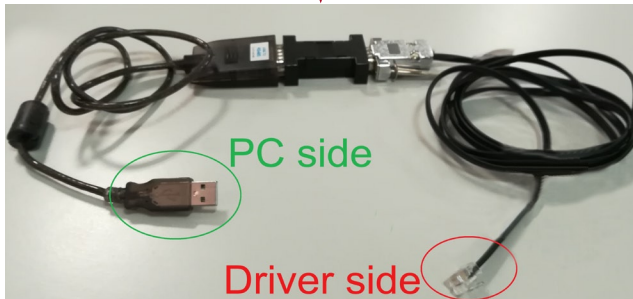

## Dip-Switches settings

### DIP2



### DIP1



*NOTE: the device reads the Dip-Switches only during the Power up. If it's necessary a setting change, shut down the system, change the settings and start up the system again to make the changes operating.*

The functionality of the Dip-Switches depends on the Firmware installed on the drive.  
(Refer to the Software Manual).



The default configuration of the DIPs is :  
- DIP1.5 and DIP1.8 = ON other contacts DIP1 = OFF  
- DIP2 = all OFF

# Display Status

## Operational statuses and their signals

C	Missing Operating System: no software application stored on drive
C	Firmware update: Updating of new software in progress.
C	Initialization: the drive executes the start-up procedure (a few seconds after the start-up procedure has begun).
C	Correct functioning
+ 1	Voltage of the DC bus near to the limit value (minimum or maximum)
+ 2	Drive temperature is near to the maximum value
+ 3	EEProm near Write Overrun
+ 8	EEProm near End of Life
flashing	Enable OFF, current zero
flashing	I <sub>nominal</sub> not computed
+ 3	Error: expired e3PLC software trial
+ 3	Security intervention of watchdog
+ 1	Internal Software Error
+ 2	Missing calibration values
+ 3	Management EEPROM
+ 4	EEPROM fail
+ 6	Error: e3PLC application error
+ 3	Error: EEPROM Write Overrun
+ 4	Error: Feature Unavailable
+ 0	Open motor phases
P + 1	Over/under voltage
P + 2	Over current on the motor output
P + 3	Over temperature of the drive;
P + 3	Missing Torque Enable ("Missing Safe Torque Off")
P + 6	Drive Over Power Protection and /or Current Regulation out of range
P + 3	e3PLC User Protection (generated by setting bit #0 of e3PLC_User_Settings)
P + 8	Motor feedback error

## Power & Logic Supply connections

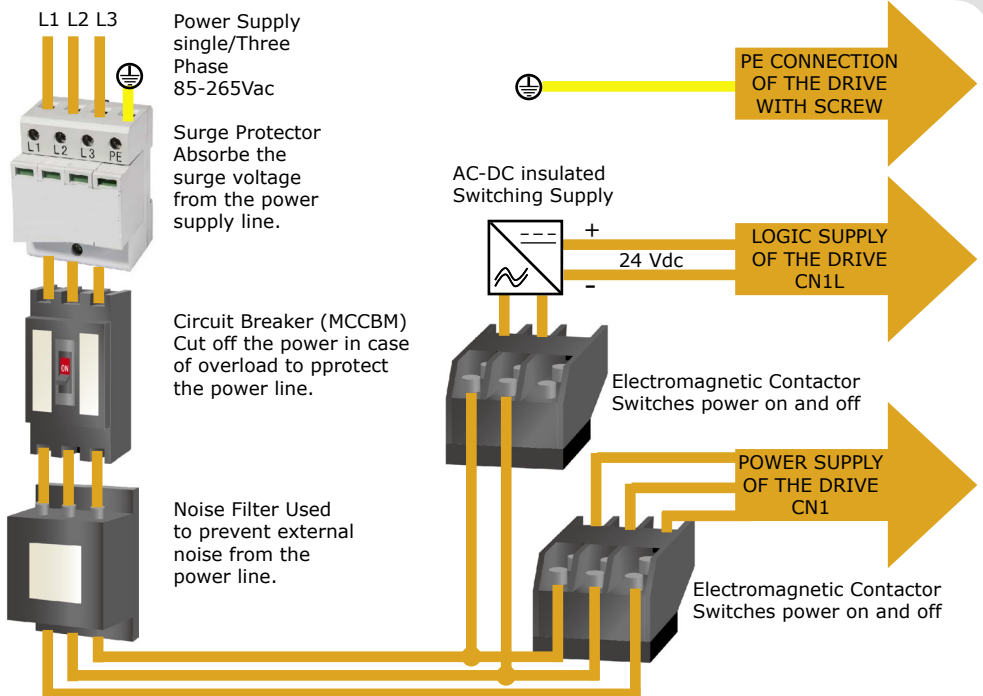

## Absolute Encoder input connection

(Maximum supply current 100mA)  
Differential 5Vdc digital inputs that meet the RS422 standard.

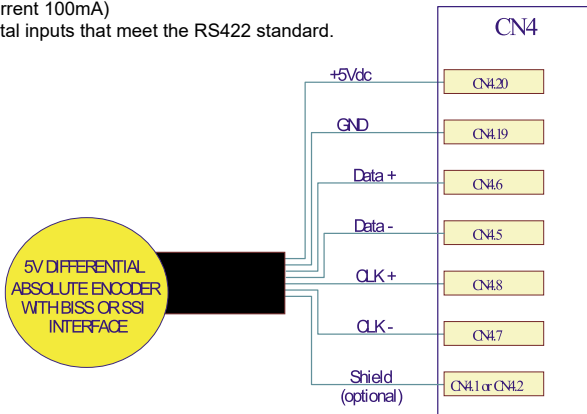

## Incremental Encoder input connection

(Maximum supply current 100mA)  
Differential 5Vdc digital inputs that meet the RS422 standard.

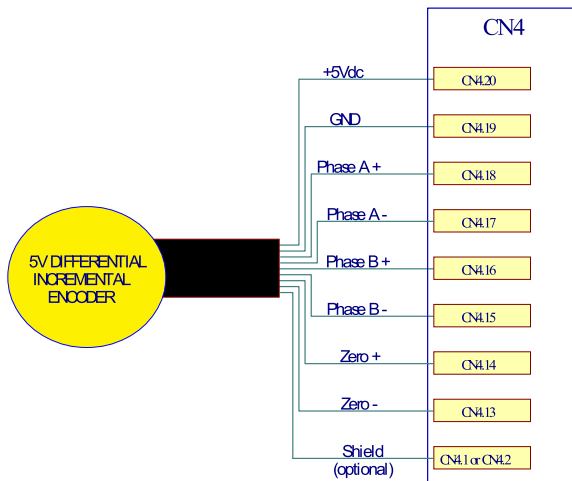

Single-Ended 5Vdc TTL/CMOS digital inputs

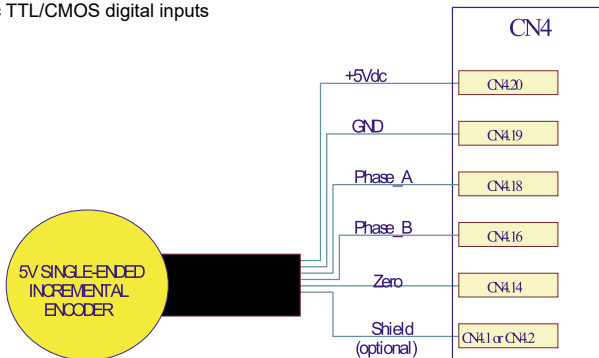

## Hall signals input connection

(Maximum supply current 100mA)  
Single-Ended 5V<sub>dc</sub> TTL/CMOS digital inputs

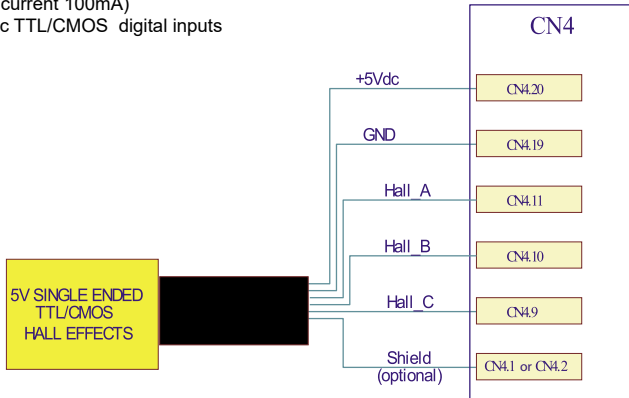

## Incremental encoder output connection

Outputs reports the used interface for encoder input: Differential or Single-Ended.  
Differential 5V digital outputs that meets RS422 standard.

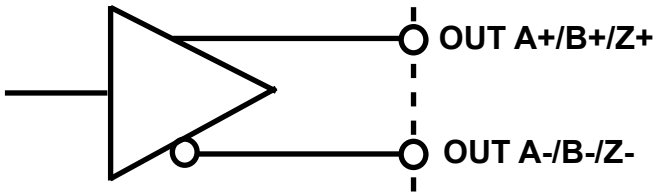

## Safe Torque Off inputs (STO)

2 terminals, 24V compatible (optoisolated)

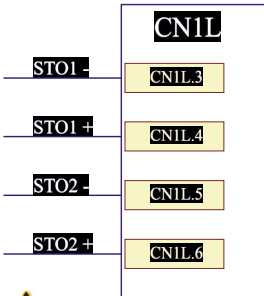

STO1	STO2	Drive Status	Motor Status
+24Vdc	+24Vdc	Enable	SW controlled
+24Vdc	Not connected	Disable	Stop for inertia
Not connected	+24Vdc	Disable	Stop for inertia
Not connected	Not connected	Disable	Stop for inertia



**STO inputs are optoisolated, shall not be used the same 24Vdc of logic supply for their connection.**

### Safety specifications

Safety function	Category	STO	Safe Torque Off
Performance Level	4		In accordance with EN ISO 13849-1
Safety Integrity Level	PLe		In accordance with EN ISO 13849-1
	SIL3		In accordance with EN ISO 13849-1 table 3
DC <sub>avg</sub> [%]	99		Average Diagnostic Coverage
PFHD [1/h]	6.44 x 10 <sup>-9</sup>		Probability of dangerous failure per hour
T Service Life [Years]	20		In accordance with EN ISO 13849-1
Type test	The STO function has been certified by an independent testing body.		



Refer to the "Safety Manual\_STO on SW5-AW5 Series" for more details of the Safe Torque Off function characteristics.

## Safe Torque Off inputs (STO)

Principle of operation:

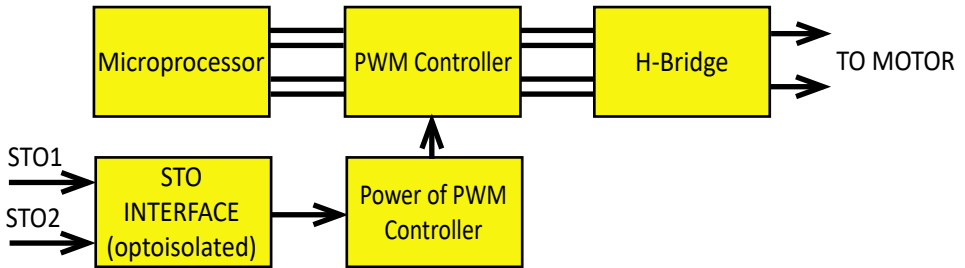

The drive has a safety feature that is designed to provide the Safe Torque Off (STO) function. Two input signals are provided which, when not connected, prevent the upper and lower devices in the PWM outputs from being operated by the digital control core. This provides a positive OFF capability that cannot be overridden by the control firmware, or associated hardware components. When both STO signals are activated (current is flowing in the input diodes of the optocouplers), the control core will be able to control the on/off state of the PWM outputs.

**i** If not using the STO feature, both signals must be connected to a 24Vdc supply in order to enable the drive.

**i** If a drive in operation mode is disabled by STO signal, it immediately finishes producing torque but the motor continues to run by inertia until it can stop.

## Braking Resistor connection

Internal circuit drives external braking resistor when the mechanical energy of the motor is converted back into electrical energy that must be dissipated before it charges the internal capacitors to an overvoltage condition.

Cut-In Voltage +DC\_BUS > 390 Vdc : output is on, external braking resistor is dissipating energy

Drop-Out Voltage +DC\_BUS < 380 Vdc : output is off, regen resistor not dissipating energy

Tolerance  $\pm 2$  Vdc for either Cut-In or Drop-Out voltage

DC Bus Capacitance : 750uF

Input voltage	Energy Absorption Capacity of the DC Bus
120Vac	46.24 joules
230Vac	17.36 joules

- INTERNAL RESISTOR

**CN7.2 and CN7.3 MUST be connected with the jumper bar (as default).**

**CN7.1 MUST remain disconnected when the internal braking resistor is used.**

The drive is equipped with an internal braking resistor of 47 $\Omega$  50W (drive mounted on appropriate heatsink).

In some applications, the internal regeneration resistor might not be enough to absorb all foldback current. In these cases, a larger wattage regeneration resistor needs to be connected externally, to prevent drive from over voltage warnings.

- EXTERNAL RESISTOR

**Before connecting an external braking resistor you MUST disconnect the jumper bar placed between CN7.2 and CN7.3.**

**CN7.3 MUST remain disconnected when an external braking resistor is used.**

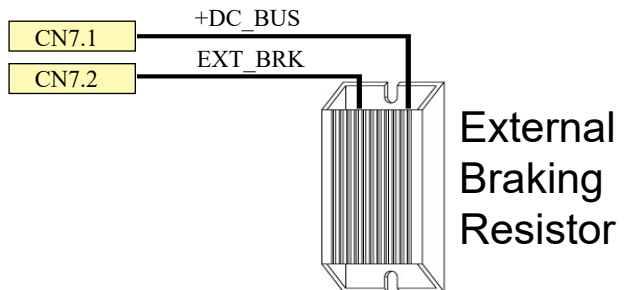

**⚠** External braking resistor must be placed more than 50mm from the drive on nonflammable and heat resistant surfaces. The metal case of the braking resistor can reach high temperatures. Take all necessary measures to avoid possible contacts in the final installation.

**⚠** +DC\_BUS is a High-Voltage circuit (up to 400Vdc) so take all necessary measures to avoid possible contacts in the final installation.





Differential PNP, NPN and Line Driver type.

### 3.3 - 24V INPUT

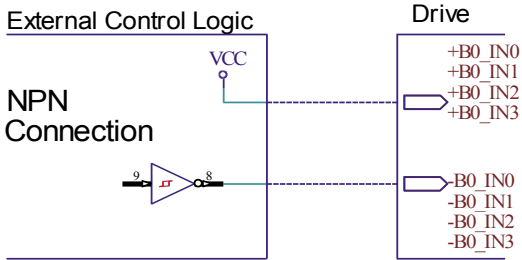
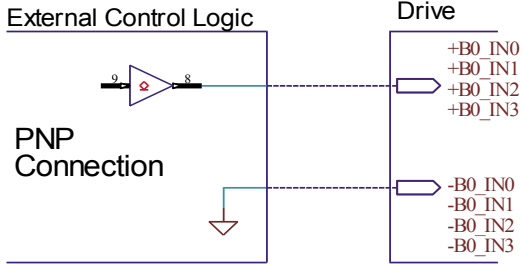

### 2 - 24V INPUT

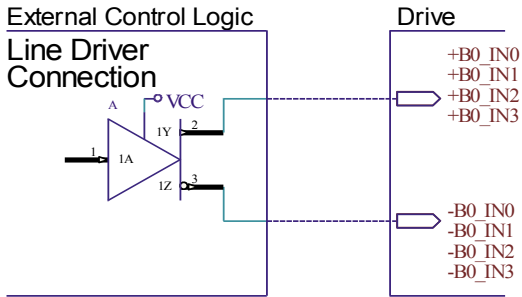

B0_IN0 and B0_IN1			
Characteristics	MIN.	MAX.	Unit
Supply voltage	2 <sup>(1)</sup>	24	Vdc
Inputs frequency	--	10	kHz
Threshold switching voltage	1.61 <sup>(1)</sup>	--	Vdc
Current at 2 Vdc	--	2.53	mA
Current at 3.3 Vdc	--	5.84	mA
Current at 5 Vdc	--	6.28	mA
Current at 24 Vdc	--	8.75	mA

B0_IN2 and B0_IN3			
Characteristics	MIN.	MAX.	Unit
Supply voltage	2 <sup>(1)</sup>	24	Vdc
Inputs frequency	--	500	kHz
Threshold switching voltage	1.61 <sup>(1)</sup>	--	Vdc
Current at 2 Vdc	--	2.53	mA
Current at 3.3 Vdc	--	5.84	mA
Current at 5 Vdc	--	6.28	mA

<sup>(1)</sup> N.B.: it's recommended to use 2 Vdc digital inputs only in differential Line-Driver configuration to have more noise immunity.

## Digital outputs connection

### Digital outputs connection (B0\_OUT0 and B0\_OUT1)



PNP with  $V_{OUTmax}=24Vdc$ ,  $I_{OUTmax}=100mA$ ,  $F_{max} = 500KHz$

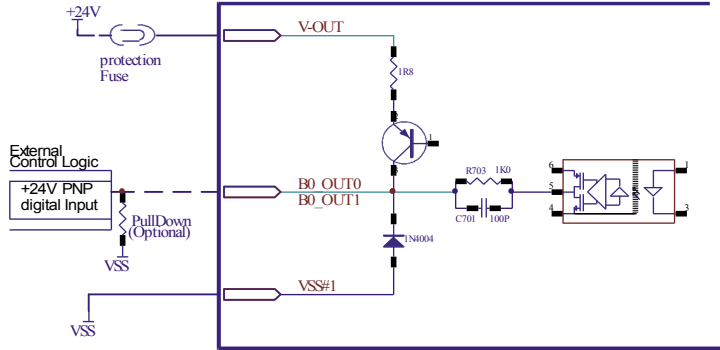

### Digital outputs connection (B0\_OUT2)



PNP with  $V_{OUTmax}=24Vdc$ ,  $I_{OUTmax}=1.3A$ ,  $F_{max} = 1KHz$

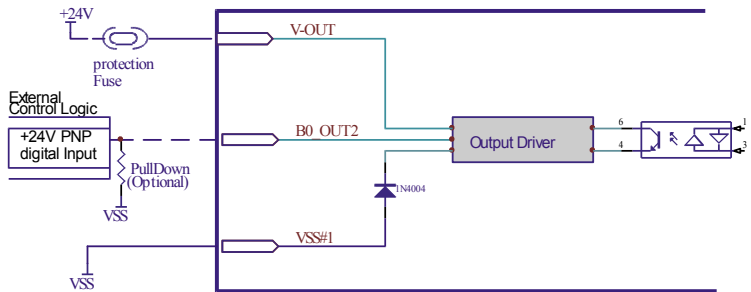

### Digital outputs connection (B0\_OUT3)



PNP with  $V_{OUTmax}=24Vdc$ ,  $I_{OUTmax}=500mA$ ,  $F_{max} = 1KHz$

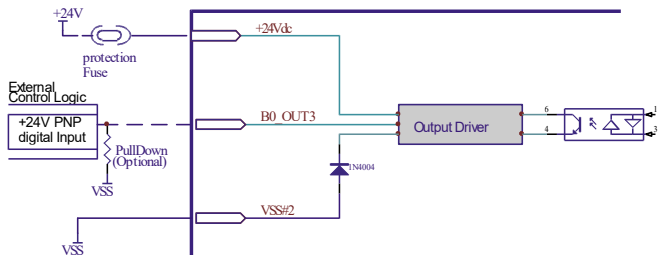

## UL regulation requirements

In order to comply with cURus certification according to the UL 61800-5-1 standard, the following requirements must be met:



### Earting system

IT or TN (not corner earthed).

The drive shall considered only for use in system voltage where the maximum voltage between the ungrounded conductors and ground does not exceed 150 V

### Maximum lenght of the cables

CABLE	LENGHT
AC Power Supply	No limitation
24VDC Logic Supply & STO	No limitation
Motor	< 30m
Feedback	< 30m
Input & Output	< 30m
Fieldbus	< 30m

### Motor and braking resistor cables must be shielded

### Fuses on AC Power Supply

In the final installation use only Cooper Bussmann FWX-20 A14F fast fuses on AC bus with 20Arms of current, 250Vac voltage and interrupt rating 200KA or any equivalent UL Listed or UL Recognized External Semiconductor Fuses, on condition that these fuses have the same ratings of the above fuse in particular with "Peak-let-trough-current Ip" and "Clearing I2t".

### Discharge time of the capacitors on the AC power supply



CAUTION – Risk of Electric Shock

Time required for the discharge of the capacitors after the removal of the AC power supply: 4 minutes.

### Dissipation



To reach the maximum performances with 100% of duty cycle, the drive shall be fixed on the side to an aluminum heat-sink with dimension of 330x305 mm with 5 mm in thickness and with an external R/C Fans, Electric (GPWV2/8) with an Air flow rate minimum of 50 m3/h positioned on the bottom side of the device like indicated in the picture above.

Use with a smaller aluminum heat-sink and a lower Fan Air Flow shall be taken into consideration in the end-use application.

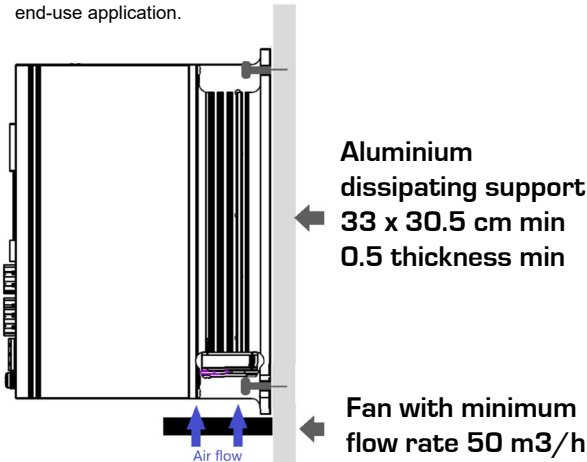

## Mating connectors

Connector	Description
CN1	Phoenix 1762208 (Green) or 1759509 (Black)
CN1L	Phoenix 1790111 (Green) or 1708329 (Black)
CN2	Phoenix 1786187 (Green) or 1701895 (Black)
CN3	Phoenix 1790153 (Green) or DFMC 1,5/ 7-ST-3,5 BK (Black)
CN4	Phoenix 1844691
CN12A / CN12B	RJ45 8 positions for Ethernet standard cables (CAT5 or higher)

## Cables section

Function	Cable	
	Minimum	Maximum
Power supply and PE	0.5 mm <sup>2</sup> (AWG20)	2.5 mm <sup>2</sup> (AWG12)
Motor output	0.5 mm <sup>2</sup> (AWG20)	2.5 mm <sup>2</sup> (AWG12)
Feedback	0.12 mm <sup>2</sup> (AWG26)	0.5 mm <sup>2</sup> (AWG20)
Logic supply and Inputs / Outputs	0.5 mm <sup>2</sup> (AWG20)	1.3 mm <sup>2</sup> (AWG16)
Fieldbus interfaces	Ethernet standard cables (CAT5 or higher)	

## Verify the installation

- Check all connection: power supply, logic supply, STO inputs and inputs/outputs
- Make sure all settings right for the application.
- Make sure the power supply is suitable for the drive.
- If possible, remove the load from the motor shaft to avoid that wrong movements cause damage.
- Enable the current to the motor and verify the applied torque.
- Enable a movement of some steps and verify if the rotation direction is the desired one.
- Disconnect the power supply, connect the load on the motor and check the full functionality.

## Analysis of malfunctions



*When one of the following situations occur, the drive doesn't function correctly and it is reported an error.*

DEFECT	CAUSE	ACTION
The external fuse to the drive burns	May be due to a wrong connection of the power supply.	Adjust the connection and recover the fuse. Use a fuse suitable for the application.
Over temperature protection.	May be due to a duty cycle	Increase the air flux and if it is possible chose a motor with higher torque at same current value.
Over current protection.	May be due to a short circuit on the motor power stage.	Shut down the power supply and check if the motor is damaged
Noisy motor movement with vibrations.	May be caused due to a state of resonance.	Increase the resolution of the step angle and/or change the motor velocity to avoid resonance area
The motor produce torque but doesn't rotate	May be caused due to a wrong connection of the I/O's.	Check the connection of the I/O's

### EVER Elettronica

Via del Commercio, 2/4 - 9/11

Loc. San Grato Z. I

26900 - L O D I - Italy

Phone +39 0371 412318 - Fax +39 0371 412367

email: infoever@everelettronica.it

web: www.everelettronica.it

